



BRICKYARD BULLETIN



VOL. 48, ISSUE 1, A MONTHLY PUBLICATION OF THE INDY CHAPTER OF THE STUDEBAKER DRIVERS CLUB, JANUARY, 2021

Hope everyone had a Merry Christmas with good food, family, and health. This crazy year has changed what and how we do many things but has also made us appreciate the things that are really important. A new and better year is coming, where we can all get back together again! The Indy Chapter will try to have monthly meetings resuming in January with our annual Pit Stop BBQ lunch.

Planning for the 57th Annual International Meet is really coming along with Swap Meet Vendors already sending in registrations for their booth rentals. It has been a little challenging contacting attractions and businesses during a pandemic but the show must go on! What we will really need going forward are local club members to help with set up, working registration, hospitality, parking, and any other things that will come up during the show, and clean up after the meet is over. With every ones help we will all have fun while hosting the best show ever! The International Club does require anyone attending the International Meet be International members so make sure your membership is up to date.

Wishing you all a Happy New Year and see everyone soon!

Nancy Bacon
Indy Club President



My daughter, Emma, spotted this Studebaker gas truck at an antique store across from the Edinburg outlet mall last week.

Charlie Griffith



I think this says it all

About Our Members



Lloyd Brownlow "Brownie" Leamon's wife Barbara just called to inform us that one of our long-time members, "Brownie" Leamon of Brownsburg, died in Hospice Thursday, December 17, 2020, at the age of 90. Lloyd had been fighting a variety of medical issues for a year and likely succumbed to COPD. His passing was not related to the COVID-19 virus.

We haven't seen "Brownie" and his 1950 Champion Starlight Coupe for some time, but I was there within the past year to help him solve a front seat track issue he was having. The car probably hasn't run in several years, but has been garaged and is well-cared for at their home in Brownsburg.

Those wishing to send a card may do so to:

Barbara Leamon
511 South Grant Street
Brownsburg IN 46112-1604



In this week's *Hendricks County Republican* that SDC / Indy Chapter member **Byron Powers** of Plainfield died the day after Christmas. A Celebration of Life will be held at a later date, per the obituary.

Byron had been a member of SDC and The Indy Chapter periodically and had at least four Studebakers of which I'm aware, plus a black 1951 or 1952 Packard 400 Patrician.

Thanks, Bob Palma



We Need Volunteers

Even though members have stepped up to be position leaders we still need volunteers to work Studebaker International. If you can work even a few hours it would be a big help. We especially need workers in hospitality, parking, registration and clean up. Please give this serious consideration and contact Joe Bacon if you are able to help. 502-553-6745 or jbwhttail@aol.com



Clearing Snow Studebaker Style

Northern Indiana winters can be bitter cold and very snowy, especially in South Bend. Winds blowing off the frigid waters of Lake Michigan can blow a few inches of snow into towering drifts. Therefore South Bend's hometown automobile manufacturer was tapped to design and build Ice Dozers for military use. As you can see from the detailed drawing, the Studebaker engineers were right on target and provided a very well built and dependable vehicle.

The T-15 Snow Weasel was manufactured in its unique white paint scheme specifically for the U.S. military during WWII. It was used on commando missions in Norway to make sure Germany wasn't installing any atomic weapons.



With a Studebaker Model 6-170 Champion 6-cylinder engine located in the back and the driver in the front, this bad boy had an operating range of a mere 165 miles at 36 mph—but it was enough. They didn't necessarily need to be fast so much as they needed to be strong, and they served that purpose well.



The initial M29 Weasel that was built by Studebaker wasn't outfitted in the white paint scheme. It was just standard old military green.

Weasels were used all over the world, including Britain, France, and Canada—but the T-15 winter prototype was only used in Norway.

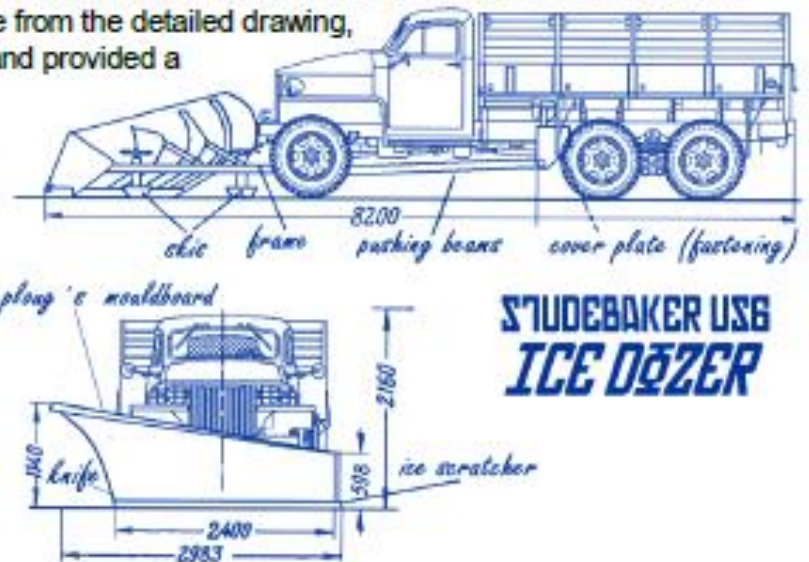

Meanwhile, back home people were struggling with daily living. Most families only owned one vehicle. There was not availability, nor finances, to have a truck and a family car.

Well, as they say... "where there's a need there's a way" ...and someone at Eshelman designed a snowplow that could be mounted on a car. Yes! While Dad was away fighting in the war, Mom and Junior could turn their trusty Studebaker into a reliable vehicle to plow snow!

ALSO Adult Eshelman 2 Pass. SPORT & GOLF CARS LOWEST PRICE 70 Miles Per Gal. Free Catalog.	ESHELMAN	CAR SNOW PLOW CLEARS ROADS & DRIVEWAYS
		Bolts on to car or truck in 2 minutes without tools. Clears snow 16" deep and 72" wide. Lightweight and sturdy. Order now, or write for free catalog.
\$39.95 COMPLETE	ESHELMAN, Dept. SP-21 109 Light St., Baltimore 2, Md. SHIPPING POINTS: Baltimore, Chicago, Reno	



Upcoming Events

Saturday, January 23 at 1:00 p.m. – Lunch at the Pit Stop in Brownsburg. Address is **932 E. Main Street**. Brownsburg, IN 46112.

Mark Your Calendar:



February – No event scheduled

Sunday, March 14 at 1:00 p.m. – Larry and Sue Kennedy will host a joint Winter Meet with the Indy Chapter of the Studebaker Drivers Club and the Southern Indiana/Kentucky Chapter of the Hudson Club. This joint meet will be held at the Franklin Township Civic League, **8822 Southeastern Avenue, Indianapolis, IN 46239** (located two houses beyond the Ordinary in downtown Wanamaker). Hosts will provide a meat dish, water, coffee and iced tea. Bring your place settings and a dish or dessert to share. This facility is handicapped accessible and has a handicap restroom, but no kitchen facilities. There are lots of electrical outlets for crockpots and plenty of parking spaces. The Indy Studebaker Chapter will have their annual fund raising auction following lunch. If you have questions, contact Larry Kennedy at 317-862-2020.



Friday May 28th and Saturday, May 29th, 2021 – Nashville, IN, - The annual Studebaker Nationals and Orphan Car Drags held in Bean Blossom Indiana. This is getting more popular each year. All performance and skill levels welcome. Nashville, Indiana, is about 40 miles South of Indianapolis and is a popular vacation destination with entertainment, shopping, camping, and motels close by so you will enjoy the visit

Racing will be Saturday the 29th so bring your car to race, or not, and come to beautiful Brown County and enjoy the day with us. There's a snack bar at the track, or bring your own picnic lunch. Also, the night before the race, Friday the 28th, at 5:30PM we meet dinner before an open house at our home for desserts. For more information about this event call Richard Poe at 812-988-2008, or roserichpoe@att.net

September 8 thru 11, 2021 – Studebaker International in Indianapolis, Indiana

Please Note: All the above dates are subject to change due to COVID Virus. Please be sure to read your Upcoming Events for changes.

The Brickyard Bulletin

Published by the Indy Chapter Studebaker Drivers Club

The Brickyard Bulletin is published monthly. The deadline for summations is the 15th of the previous month.

We hereby give permission to other S.D.C. chapters to use information from the newsletter when proper credit is given. *“Reprinted or Reproduced from the Indy Chapter, Brickyard Bulletin.”*

Indy Chapter Officers

President: Nancy Bacon, 1701E. Lawrence Ave., Indianapolis, IN 46227 at nancyjb1701@aol.com or 317-783-4721

V. President: Diane Elmore 699 S Co Rd 400 E, Avon, IN 46123 at delmore@hotmail.com or 317-745-5616

Secretary: Sandy Fox, 7956 Oak Hill Dr., Plainfield, IN 46268, at bsfox@att.net or 317-839-4361

Treasurer: Tom Flynn, 4531 S CR 500 E, Plainfield, IN 46168, at tom_and_trudy@yahoo.com or 317-837-5671

Activities: Charlie Griffith, 1526 S. Hunter Rd., Indianapolis, IN 46239, at chazwork@msn.com or 317-353-8287

Editor: Becky Griffith, 1526 S. Hunter Rd., Indianapolis, IN 46239, at becinin@msn.com or 317-353-8287

In addition

Web Designer: Jeff Westcott at www.indychaptersdc.org

Facebook: Larry Hopkins at Studebakers in Indy or <https://www.facebook.com/groups/634984973222050/>

National Directors

President: Dennis Foust - studeguy54@gmail.com

Vice President:

Secretary: Cindy Foust - cfoust1966@gmail.com

Treasurer: Jane Stinson - jestinson@aol.com

Past President: Tom Curtis - tomnancurtis@aol.com

National Board of Directors

Crossroads Zone National Board Director: Bob Henning at rhnn15090@aol.com

Crossroad Zone Coordinator: Joanne Hamblin

Regional Manager Indiana: Bob Henning

National SDC Membership

Regular membership dues in the National Studebaker Club are \$24.00 for new members 1st year only. Renewals are \$31.00 per year, which includes 12 monthly issues of *Turning Wheels*, the National SDC Magazine. (Other memberships are available.) Application is available upon request or e-mail studebakerdriverclub.com.

National SDC membership is a prerequisite. Renewal INDY Chapter dues are \$18.00. Renewals are payable January each year. After March a \$5.00 late fee will be added. Application is available upon request.

Updated October, 2020

Brickyard Bulletin January, 2021



Jeff Westcott's 1962 Lark Daytona decked out for the holidays.

Indy Chapter SDC
Becky Griffith, Editor
1526 S. Hunter Rd
Indianapolis, IN 46239

To:

HAPPY
2021
NEW YEAR